



GFCI (Ground Fault Circuit Interrupter) Devices

GFCI Receptacles

Shanghai Linsky large selection of GFCIs includes Tamper-Resistant (TR) GFCI devices that meet Section 406.11 of the 2008 code and help protect children from electrical shock. For the highest level of ground fault protection stall 2008 NEC® code compliant Weather-Resistant GFCI (WR) receptacles, which meet UL 498 requirements. Built with UV stabilized engineering thermoplastic, the devices have high cold impact resistance and feature stainless steel straps and mounting screws.

Heavy duty double wipe for 15Amp contacts and triple wipe for 20 and triple wipe for 20Amp contacts

Red LED Indicator:
Flash 2 seconds for power on

Patented lockout feature for added safety prevents "RESET" if GFCI is not operating properly



Expanded wiring options with eight back-wire holes (two for each line and load connection) plus ground with internal clamp



Impact-resistant thermoplastic nylon cover and body

Green LED Indicator:
ON: GFCI function works after press "RESET" button
OFF: Press "TEST" button

Triple drive combination terminal screws



TR Symbol on GFCI receptacles assures they meet the 2008 NEC Requirement



Dual Function LED offers indication of line/load reversal and power availability.



Lockout action blocks the "RESET" button if GFCI protection has been compromised.



WR designed for wet and damp locations, required by NEC®Section 406.8



Self-Test

- ◆ New Version UL 943 Standard now requires newly manufactured GFCIs to be auto-monitoring(self-testing) by conducting and internal test to confirm that protected power is available
- ◆ Provides continuous ground fault protection
- ◆ On initial power up, tests the GFCI within 1 second
- ◆ Self test(Auto-monitoring) exceeds the new version UL requirement
- ◆ Testing every two hours updates the protection status
- ◆ Auto adapts and shifts to more frequent testing if potential problem is detected



Tamper Resistant

- ◆ Complies with NEC® requirement, all 15A and 20A receptacles installed in dwelling units should be with tamper-resistant
- ◆ Receptacles with Shutter mechanism block access to the contacts unless the plug is fully inserted



Weather Resistant

- ◆ Designed for wet and damp locations, required by NEC® Section 406.8
- ◆ Anti-ultraviolet plastics
- ◆ Cold impact resistant
- ◆ Operating Temperature from -35 °C to 66 °C
- ◆ Stainless steel strap and screws





- ◆ Bride contact provides individual sets of contacts for GFCI receptacle face and downstream receptacles. No power will be delivered to receptacle face if improperly wired(line-load reversed)
- ◆ Trip threshold meets UL requirements for stripping time (0.025s)
- ◆ Less nuisance tripping to high frequency noise
- ◆ Provides superior resistance to electrical surges and over-voltages
- ◆ Lockout Action prevents reset if GFCI is damaged or don't have respond to a ground fault
- ◆ Status Indicator Light provides simple, intuitive feedback on power, voltage and protection status as well as end of life
- ◆ Silver alloy contacts
- ◆ Self-test every 140 mins to ensure continuous safety
- ◆ Impact-resistan thermoplastic cover and body
- ◆ One piece T-design strip latch mechanism provides efficient operation
- ◆ Available in 15A and 20A versions, all with Fed-through
- ◆ TEST and RESET button colors match device face
- ◆ Compatible with all the wallbox and probide matched



Dimensions Information

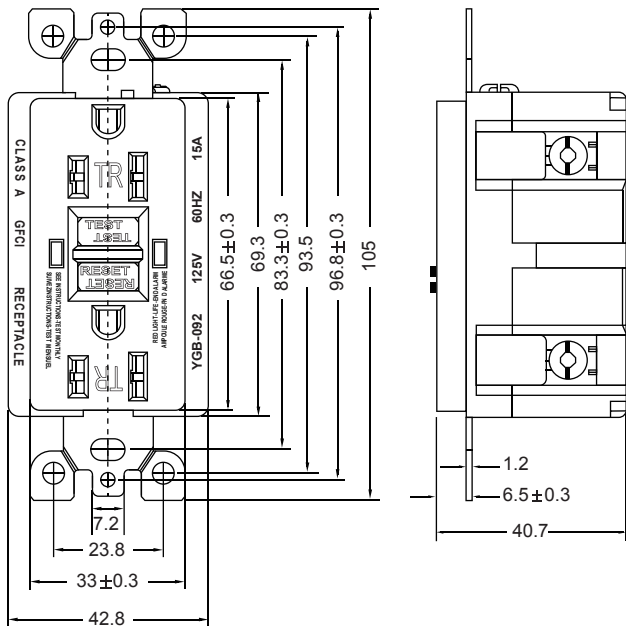

Tamper Resistant 15A GFCI

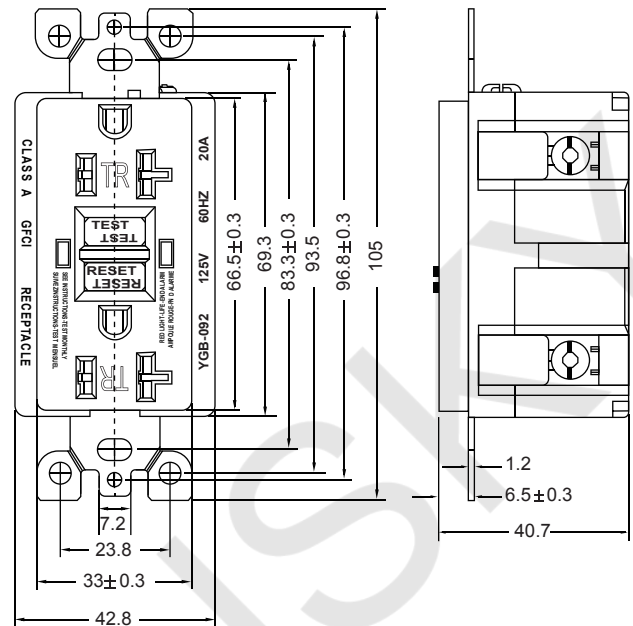

Tamper Resistant 20A GFCI

Specification of our package



Product Name: GFCI outlet
 QUANTITY: 100PCS
 CARTON SIZE: 39*31*24CM
 Gross Weight: 15.2kg



Product Name: GFCI outlet with wall plate
 QUANTITY: 50PCS
 CARTON SIZE: 49*24*24CM
 Gross Weight: 9.5kg



Product Display



Ordering Information

Cat.No.	Description	Main Feature	Rating	Color
LTG15	15A 125V 60HZ GFCI Receptacle	Self Testing With LED Indicator Light (With self-grounding clips)	15AMP 125V	White Ivory Gray Black Almond Brown Red
LTG20	20A 125V 60HZ GFCI Receptacle	Self Testing With LED Indicator Light (With self-grounding clips)	20AMP 125V	White Ivory Gray Black Almond Brown Red
LTG15TR	15A 125V 60HZ GFCI Receptacle With Tamper	Tamper Resistant GFCI Self Testing With LED Indicator Light (With self-grounding clips)	15AMP 125V	White Ivory Gray Black Almond Brown Red
LTR20TR	20A 125V 60HZ GFCI Receptacle With Tamper	Tamper Resistant GFCI Self Testing With LED Indicator Light (With self-grounding clips)	20AMP 125V	White Ivory Gray Black Almond Brown Red
LTG15WR	15A 125V 60HZ GFCI Receptacle With Weather	Weather Resistant GFCI Self Testing With LED Indicator Light (With self-grounding clips)	15AMP 125V	White Ivory Gray Black Almond Brown Red
LTG20WR	20A 125V 60HZ GFCI Receptacle With Weather	Weather Resistant GFCI Self Testing With LED Indicator Light (With self-grounding clips)	20AMP 125V	White Ivory Gray Black Almond Brown Red



Cat.No.	Description	Main Feature	Rating	Color
LTG15TR-WR	15A 125V 60HZ GFCI Receptacle With Tamper Resistant & Weather Resistant	Tamper Resistant & Weather Resistant GFCI Self Testing With LED Indicator Light (With self-grounding clips)	15AMP 125V	White Ivory Gray Black Almond Brown Red
LTG20TR-WR	15A 125V 60HZ GFCI Receptacle With Tamper Resistant & Weather Resistant	Tamper Resistant & Weather Resistant GFCI Self Testing With LED Indicator Light (With self-grounding clips)	20AMP 125V	White Ivory Gray Black Almond Brown Red
TSI	20A 125V 60HZ Faceless GFCI	Self Testing With LED Indicator Light (With self-grounding clips)	20AMP 125V	White Ivory Gray Black Almond Brown Red
LTG15-NL	15A 125V 60HZ GFCI Receptacle, No Load	Self Testing With LED Indicator Light (With self-grounding clips)	15AMP 125V	White Ivory Gray Black Almond Brown Red
LTG20-NL	20A 125V 60HZ GFCI Receptacle, No Load	Self Testing With LED Indicator Light (With self-grounding clips)	20AMP 125V	White Ivory Gray Black Almond Brown Red
LTG15TR-NL	15A 125V 60HZ GFCI Receptacle With Tamper Resistant, No Load	Tamper Resistant GFCI Self Testing With LED Indicator Light (With self-grounding clips)	15AMP 125V	White Ivory Gray Black Almond Brown Red
LTG20TR-NL	20A 125V 60HZ GFCI Receptacle With Tamper Resistant, No Load	Tamper Resistant GFCI Self Testing With LED Indicator Light (With self-grounding clips)	20AMP 125V	White Ivory Gray Black Almond Brown Red
LTG15WR-NL	15A 125V 60HZ GFCI Receptacle With Weather Resistant, No Load	Weather Resistant GFCI Self Testing With LED Indicator Light (With self-grounding clips)	15AMP 125V	White Ivory Gray Black Almond Brown Red
LTG20WR-NL	20A 125V 60HZ GFCI Receptacle With Weather Resistant, No Load	Weather Resistant GFCI Self Testing With LED Indicator Light (With self-grounding clips)	20AMP 125V	White Ivory Gray Black Almond Brown Red
LTG15TR-WR-NL	15A 125V 60HZ GFCI Receptacle With Tamper Resistant & Weather Resistant, No Load	Tamper Resistant & Weather Resistant GFCI Self Testing With LED Indicator Light (With self-grounding clips)	15AMP 125V	White Ivory Gray Black Almond Brown Red
LTG20TR-WR-NL	15A 125V 60HZ GFCI Receptacle With Tamper Resistant & Weather Resistant, No Load	Tamper Resistant & Weather Resistant GFCI Self Testing With LED Indicator Light (With self-grounding clips)	20AMP 125V	White Ivory Gray Black Almond Brown Red



GFCI SAFETY OUTLET TAMPER RESISTANT GROUND FAULT CIRCUIT INTERRUPTER

INSTALLATION AND TESTING

**15A120V 60HZ
20A120V 60HZ**

**Please read this manual completely
before installing**

CAUTION

- To prevent severe shock or electrocution, always turn the power OFF at the service panel before working with the wiring.
- Use this GFCI receptacle with copper or copper-clad wire. Do not use it with aluminum wire.
- Do not install this GFCI receptacle on a circuit that powers life support equipment because if the GFCI trips, it will shut down the equipment.
- For installation in wet locations, protect the GFCI receptacle with a weatherproof cover that will keep both the receptacle and any plugs dry.
- Must be installed in accordance with national and local electrical codes.

Tamper resistant mechanism stops access to outlet contacts unless a two-prong plug is inserted.

1. What is a GFCI?

A GFCI receptacle is different from conventional receptacles. In the event of a ground fault, a GFCI will trip and quickly stop the flow of electricity to prevent serious injury.

Definition of a ground fault: Instead of following its normal safe path, electricity passes through a person's body to reach the ground. For example, a defective appliance can cause a ground fault.

A GFCI receptacle does not protect against circuit overload, short circuits, or shocks. For example, you can still be shocked if you touch bare wires while standing on a conducting surface such as cement or grease.

2. The GFCI's features

FRONT VIEW

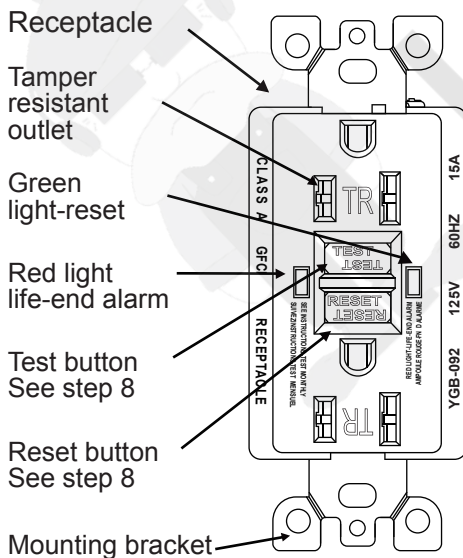

BACK VIEW

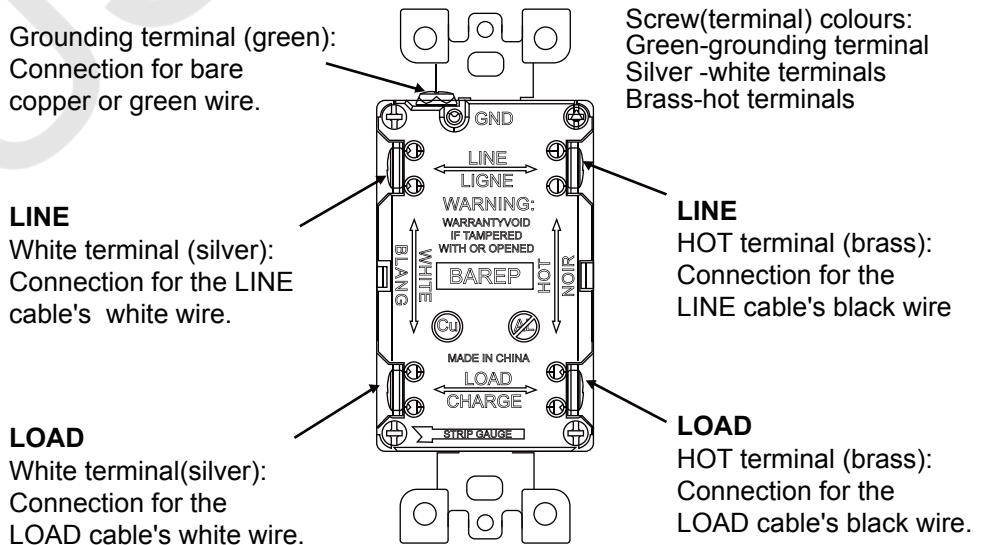

3. Should you install it?

Installing a GFCI receptacle can be more complicated than installing a conventional receptacle.

Make sure that you:

- Understand basic wiring principles and techniques.
- Can interpret wiring diagrams.
- Have circuit wiring experience.
- Are prepared to take a few minutes to test your work, making sure that you have wired the GFCI receptacle correctly.

If you do not fully understand these instructions, you should seek the assistance of a qualified electrician.

6. Identify cables/wires

IMPORTANT: Do not install the GFCI receptacle in an electrical box containing (a) more than 4 wires (not including the ground wires) or (b) cables with more than two wires (not including the ground wire). Contact a qualified electrician if either (a) or (b) is true.

- If you are replacing an old receptacle, pull it out of the electrical box without disconnecting the wires.
- If you see one cable (2-3 wires) it is the LINE cable. The receptacle is probably in position C (see diagram to the right). Remove the receptacle and go to step 7A.
- If you see two cables (4-6 wires), the receptacle is probably in position A or B (see diagram to the right). Follow steps a-e of the procedure to the right.

4. Line vs load

A cable consists of 2 or 3 wires.

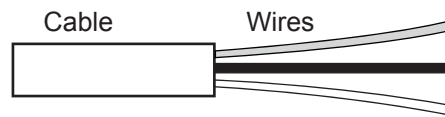

LINE CABLE: Delivers power from the service panel (breaker panel or fuse box) to the GFCI. If there is only one cable entering the electric box, it is the LINE cable. This cable should be connected to the GFCI's LINE terminals only.

LOAD CABLE: Delivers power from the GFCI to another receptacle/outlet in the circuit. This cable should be connected to the GFCI's LOAD terminals only. The LOAD terminals are under the yellow sticker. Do not remove the sticker at this time.

5. Turn the power off.

Plug an electrical device, such as a lamp or radio, into the receptacle on which you are working. Turn the lamp or radio on. Then, go to the service panel. Find the breaker or fuse that protects that receptacle. Place the breaker in the OFF position or completely remove the fuse. The lamp or radio should turn OFF.

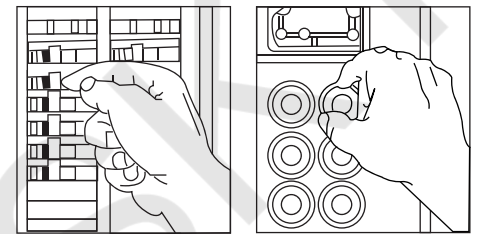

Procedure: box with two cables (4-6 wires)

- Detach one cable's white and hot wires from the receptacle and cap each one separately with a wire connector. Make sure that they are from the same cable.
- Reinstall the receptacle in the electrical box, attach the wall plate, then turn the power ON at the service panel.
- Determine if power is flowing to the receptacle. If so, the capped wire are the LOAD wires. If not, the capped wires are the LINE wires.
- Turn the power off at the service panel. Label the LINE and LOAD wires, then remove the receptacle.
- Go to step 7B.

Placement in circuit:

The GFCI's place in the circuit determines if it protects other receptacles/outlets in the circuit.

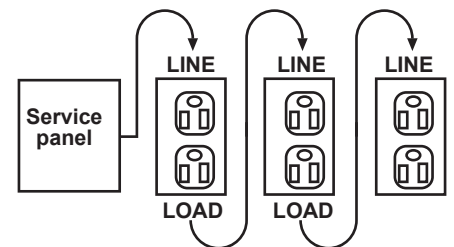

Sample circuit:

Placing the GFCI in position A will also provide protection to "load side" receptacles/outlets B and C. On the other hand, placing the GFCI in position C will not provide protection to receptacles/outlets A or B. Remember that receptacles/outlets A, B and C can be in different rooms.



7.Connection the wires(choose A or B)...only after reading other side completely

A:One cable(2-3) entering the box

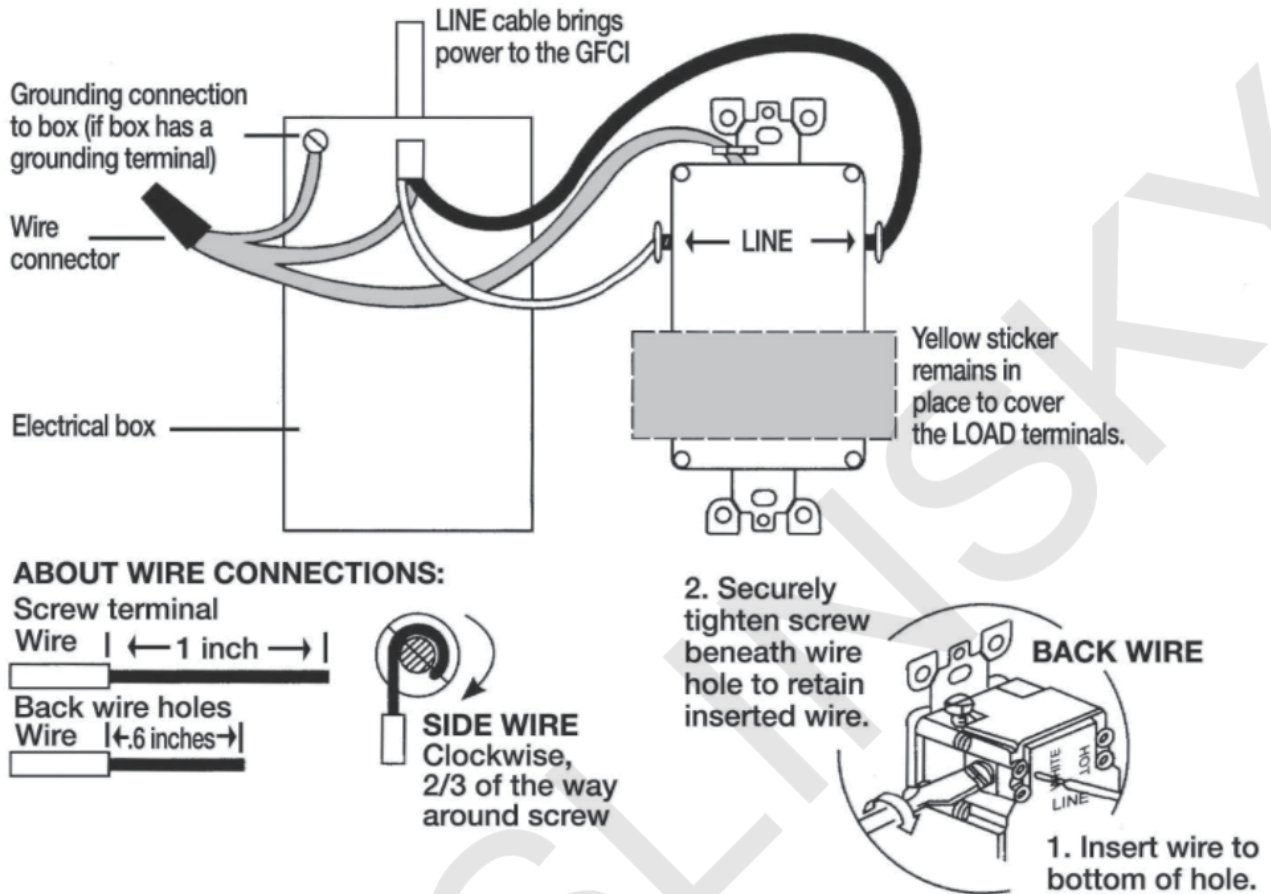

Connect the LINE cable wires to the LINE terminals:

- The white wire connects to the white terminal (silver)
- The black wire connects to the hot terminal (brass)

Connect the ground wire (only if there is a ground wire):

- For a box with no ground terminal (diagram not shown): Connect the LINE cable's bare copper (or green) wire directly to the ground terminal on the GFCI receptacle.
- For a box with a ground terminal (diagram shown above): Connect a 6 inch bare copper (or green) 12 or 14AWG wire to the ground terminal on the GFCI.
- Also connect a similar wire to the ground terminal on the box. Connect the ends of these wires to the LINE cable's bare copper (or green) wire using a wire connector. If these wires are already in place, check the connections.

Complete the installation:

- Fold the wires into the box, keeping the ground wire away from the white and hot terminals. Screw the receptacle to the box and attach the wall plate.
- Go to step 8.



B: Two cable(4or6) entering the box

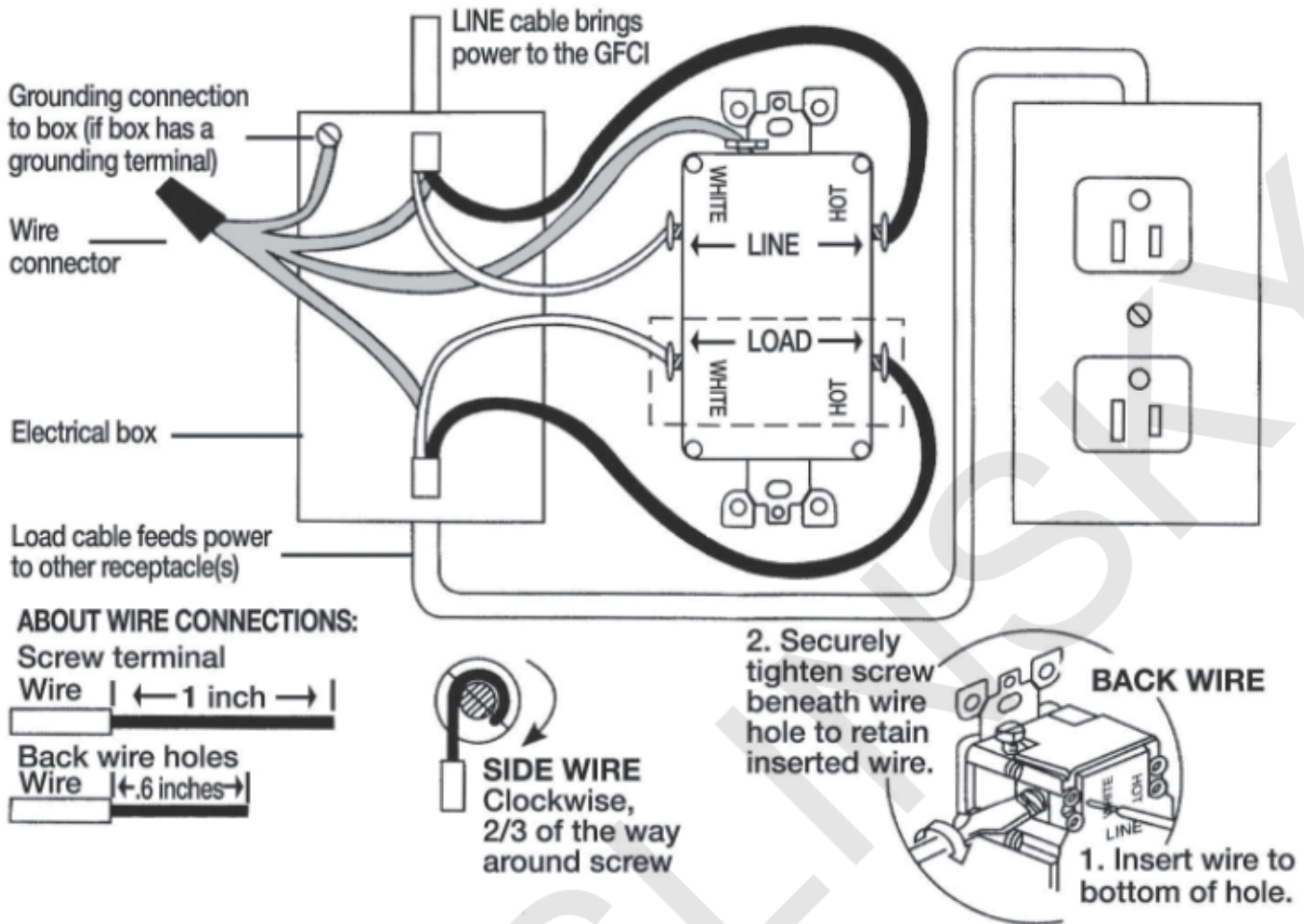

Connect the LINE cables wires to the LINE terminals:

The white wire connects to the white terminal (silver)

The black wire connects to the hot terminal (brass)

Connect the LOAD cable wires to the LOAD terminals:

- Remove the yellow sticker to reveal the LOAD terminals

- The white wire connects to the white terminal (silver)

- The black wire connects to the hot terminal (brass)

Connect the ground wires as shown above (only if there is a ground wire):

- Remove the yellow sticker to reveal the LOAD terminals

- The white wire connects to the white terminal (silver)

- The black wire connects to the hot terminal (brass)

Connect the ground wires as shown above (only if there is a ground wire):

- Connect a 6 inch bare copper (or green) 12 or 14 AWG wire to the ground terminal on the GFCI. If the box has a ground terminal, also connect a similar wire to the ground terminal on the box. Connect the ends of these wires to the LINE and LOAD cable's bare copper (or green) wire using a wire connector. If these wires are already in place, check the connections.

Complete the installation:

- Fold the wires into the box, keeping the ground wire away from the white and hot terminals. Screw the receptacle to the box and attach the wall plate.

- Go to step 8



8. Test you work

Why perform this test?

If you miswire the GFCI it may not prevent personal injury or death due to a ground fault (electrical shock).

If you mistakenly connect the LINE wires to the LOAD terminals, the GFCI will not reset and will not provide power to either the GFCI receptacle face or any receptacles fed from the GFCI.

Procedure:

a. This GFCI is shipped from the factory in the tripped condition and cannot be reset until the Line and Load are wired correctly and power is supplied to the device. Turn the power ON at the service panel. Press the RESET button fully. If the indicator (LED) glows green, you have installed the GFCI receptacle correctly.

Plug a lamp or radio into the GFCI (and leave it plugged in). Ensure that the GFCI can be tripped by pressing the TEST button. If the GFCI receptacle cannot be reset, the indicator (LED) does not glow, and there is no power in the lamp or radio, go to the Troubleshooting because LINE and LOAD wiring connections have been reversed.

b. Press the test button in order to trip the device. This should stop the flow of electricity, making the radio or lamp shut off. Note that the reset button will pop out. If the power goes off, the green indicator (LED) goes out, you have installed the GFCI receptacle correctly. To restore power, press the reset button.

c. If you installed your GFCI using step 7B, plug a lamp or radio into surrounding receptacles to see which one(s), in addition to the GFCI, lost power when you pressed the test button. Do not plug life saving devices into any receptacles that lost power. Place a "GFCI Protected" sticker

d. Press the test button (then reset button) every month to assure proper operation. In case the life-end indicator (Red LED) is off the GFCI will still provide ground fault protection.

e. The GFCI includes an end-of-life monitoring function. When a GFCI receptacle is incapable of passing its internal test function (it can no longer provide ground fault protection), one of the following alarm indications will be present:

i. When the GFCI reaches the end of its' life the red indicator will turn on. The GFCI must be replaced.

TROUBLESHOOTING

Turn the power off and check the wire connections against the appropriate wiring diagram in step 7A or 7B. Make sure that there are no loose wires or loose connections.

Also, it is possible that you reversed the line and load connections if the GFCI can not be reset and there is no power at the receptacle. Start the test from the beginning of step 8 if you rewired any connections to the GFCI. The GFCI includes an end of life monitoring function. When a GFCI receptacle is incapable of passing its internal test function (it can no longer provide ground fault protection) one of the following alarm indications will be present: When the GFCI reaches the end of its' life the red indicator will turn on. The GFCI must be replaced. If there is no power output the GFCI has reached the end of its' life. The GFCI must be replaced.

15A 120V 60Hz

20A 120V 60Hz

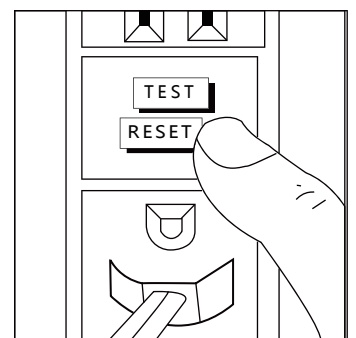
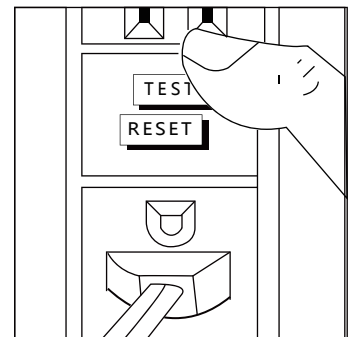
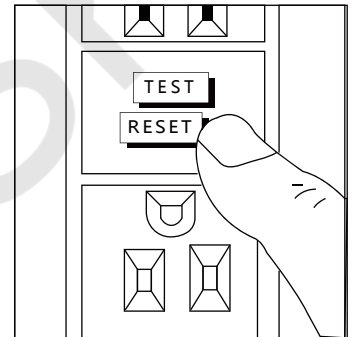

CERTIFICATE OF COMPLIANCE

Certificate Number E491779
Report Reference E491779-20170425
Issue Date 2020-June-02

Issued to: SHANGHAI LINSKY ELECTRICAL CO.,LTD
NO.14, LANE 1515 YUANDONG RD, FENGXIAN
DISTRICT
201400 SHANGHAI, CHINA

**This certificate confirms that
representative samples of**

Ground-fault Circuit Interrupters
See Addendum page

Have been investigated by UL in accordance with the
Standard(s) indicated on this Certificate.

Standard(s) for Safety: UL 943 and CSA C22.2 No. 144.1-16-GROUND-FAULT
CIRCUIT-INTERRUPTERS

Additional Information: See the UL Online Certifications Directory at
<https://iq.ulprospector.com> for additional information.

This *Certificate of Compliance* does not provide authorization to apply the UL Mark. Only the UL Follow-Up Services Procedure provides authorization to apply the UL Mark.

Only those products bearing the UL Mark should be considered as being UL Certified and covered under UL's Follow-Up Services.

Look for the UL Certification Mark on the product.



Bruce Mahrenholz, Director North American Certification Program
UL LLC

Any information and documentation involving UL Mark services are provided on behalf of UL LLC (UL) or any authorized licensee of UL. For questions, please contact a local UL Customer Service Representative at <http://ul.com/aboutul/locations/>



CERTIFICATE OF COMPLIANCE

Certificate Number E491779
Report Reference E491779-20170425
Issue Date 2020-June-02

This is to certify that representative samples of the product as specified on this certificate were tested according to the current UL requirements.

Models/Product:

Receptacle auto-monitoring ground-fault circuit interrupters-LTG15, LTG15-NL, LTG20, LTG20-NL

Receptacle auto-monitoring ground-fault circuit interrupters, tamper resistant-LTG15TR, LTG15TR-NL, LTG20TR, LTG20TR-NL

Receptacle auto-monitoring ground-fault circuit interrupters, tamper resistant and weather resistant-LTG15TR-WR, LTG15TR-WR-NL, LTG20TR-WR, LTG20TR-WR-NL

Receptacle auto-monitoring ground-fault circuit interrupters, weather resistant-LTG15WR, LTG15WR-NL, LTG20WR, LTG20WR-NL

Receptacle Auto-Monitoring Ground Fault Circuit Interrupters
LTG15-1
LTG20-1

Receptacle Auto-Monitoring Ground Fault Circuit Interrupters, Tamper Resistant
LTG15TR-1
LTG20TR-1

Receptacle Auto-Monitoring Ground Fault Circuit Interrupters, Weather Resistant
LTG15WR-1
LTG20WR-1

Receptacle Auto-Monitoring Ground Fault Circuit Interrupters, Tamper Resistant and Weather Resistant
LTG15TRWR-1
LTG20TRWR-1



Bruce Mahrenholz, Director North American Certification Program
UL LLC

Any information and documentation involving UL Mark services are provided on behalf of UL LLC (UL) or any authorized licensee of UL. For questions, please contact a local UL Customer Service Representative at <http://ul.com/aboutul/locations/>



SHANGHAI LINSKY ELECTRICAL CO.,LTD

 +86-21-67107908

 sales@linsky.cn

 www.shlinsky.com

 Office Add : Room 1002, #2 Building, Phoenix Creativity
Valley, Lane 1588 Huhang Highway, Fengxian, SH

Factory Add: #29, Lane 1888 Daye Highway, Fengxian, SH